



RDOX® Optical Dissolved Oxygen Probe

THE RUGGED DISSOLVED OXYGEN (RDO) RDOX PROBE USES OPTICAL TECHNOLOGY TO MEASURE DISSOLVED OXYGEN (DO) IN DRINKING WATER TREATMENT AND DEMANDING WASTEWATER PROCESS ENVIRONMENTS.



The RDOX sensor responds quickly to oxygen and temperature changes for efficient and effective monitoring of drinking water and wastewater influent, effluent and treatment processes.

LOW-MAINTENANCE

- Operates with very low drift for long periods of time.
- Responds quickly and accurately to oxygen and temperature changes across the full range.
- Delivers consistent, reproducible results (<0.05 mg/L).
- Doesn't require membranes and filling solutions.
- Doesn't require hydration conditioning, delivers accurate data within 90 seconds of going from dry to wet conditions.

INTEGRATED DESIGN

- Automated, error-free setup with calibration coefficients loaded directly into the sensor cap.
- Flexible communications: Standard 4-20 mA, Modbus/RS485, direct or using the 7300 monitor with local display.
- Direct connection option to eliminate the need for a transmitter or controller; requires only 8 to 36 VDC power.

COST EFFECTIVE

- Run aerators efficiently reducing energy use.
- Use twist-lock cable connection and quick-connect mount to interchange In-Situ sensors.
- Easily view and filter data using In-Situ telemetry systems and HydroVu™ data services.

ROBUST CONSTRUCTION

- Resists abrasion and photobleaching effects.
- Inert, non-corrosive material withstands wastewater environments.
- Available in stainless steel for the most challenging environments.
- Insensitive to interferences that plague membrane-based sensors (hydrogen sulfide, chloride, ammonium, and others).

Applications:

- WASTEWATER TREATMENT
- INDUSTRIAL WATER
- MUNICIPAL DRINKING WATER

RDOX OXYGEN SENSOR

SENSOR TYPE.	Optical DO probe uses Classic Sensor Cap.
RANGE, DO	0 to 60 mg/L
ACCURACY, DO	±0.1 mg/L, 0 to 20 mg/L ±2% of reading, 20 to 60 mg/L
RESOLUTION, DO	0.01 mg/L
RESPONSE TIME, CAP	T90: <45 sec. T95: <60 sec. @ 25° C (77° F)
RANGE, TEMP.	0° to 50° C (32° to 122° F)
ACCURACY, TEMP.	±0.1° C (±1.8° F) typical
RESOLUTION, TEMP.	0.01° C (0.18° F)
SALINITY, COMP.	Fixed or real-time capable
BAROMETRIC COMP.	Fixed or real-time capable
METHODS	EPA-approved In-Situ® RDO methods 1002-8-2009, 1003-8-2009, 1004-8-2009 Standard Methods 4500-O
WEIGHT	1.21 kg (2.269 lbs)

ENVIRONMENTAL RATINGS

PRESSURE	150 psi from 0° to 50° C (32° to 122° F); 300 psi @ 25° C (77° F)
DEPTH	210 m (689 ft) @ 25° C (77° F)
OPERATING TEMP.	Probe: 0° to 50° C (32° to 122° F)
STORAGE TEMP.	Sensor cap: 1° to 60° C (33° to 140° F), in factory container Probe: -5° to 60° C (23° to 140° F)
COMPLIANCE	Heavy industrial, IEC 61000-6-2:2005, EMC 2014/30/EU
IP RATING	IP-67 with cap off; IP-68 with cap installed

CHEMICAL RATINGS

INTERFERENCES	Alcohols >5%; hydrogen peroxide > 3%; sodium hypochlorite (commercial bleach) > 3%; gaseous sulfur dioxide; gaseous chlorine. Do not use in organic solvents (e.g., acetone, chloroform, methylene chloride, etc.), which may swell the sensing element (foil matrix) and destroy it.
---------------	---

GENERAL RATINGS

COMMUNICATION OUTPUT	Modbus/RS485, SDI-12, 4-20 mA
POWER REQUIREMENTS	8 to 36 VDC
POWER CONSUMPTION	Maximum: 50 mA at 12 VDC
CABLE LENGTHS	Modbus and 4-20 mA: Up to 1,219 m (4,000 ft) SDI-12: Up to 61 m (200 ft)
INT. MOUNTING	ChemScan quick connect fitting
WARRANTY	Probe: 3 years from date of shipment Cap: 2 years in typical applications

Specifications RDOX sensor in ABS housing (subject to change without notice.)

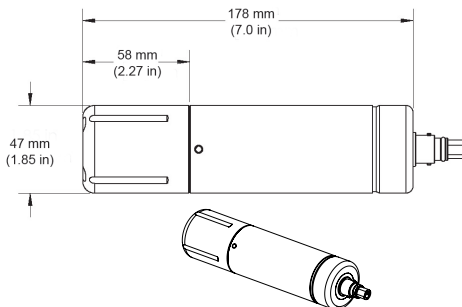

Dimensions for the stainless steel RDOX sensor:
47 mm (1.85 in) OD x 220 mm (8.65 in) including Twist Lock bulkhead, 192 mm (7.56 in) without Twist Lock bulkhead

KEY ADVANTAGES

- **Long-lasting calibration**—the sensor maintains calibration and operates with no drift over long-term deployments, delivering consistent, reproducible results.
- **Automatic setup**—the RDOX Cap is pre-loaded with factory calibration coefficients, serial number and manufacture date.
- **Sensor-health diagnostics**—internal indicators provide alerts on excessive wear and reminders for regular maintenance.
- **Fast response**—with patented signal processing, the sensor responds quickly and maintains stability, even in dynamic conditions.

TECHNOLOGY

When the RDOX probe initiates a reading, a blue LED emits blue light, which excites lumiphore molecules in the sensing element. Excited lumiphore molecules emit red light, which is detected by a photodiode. Oxygen molecules quench the excited lumiphore molecules and prevent the emission of red light—a process called “dynamic luminescence quenching.” Determination of DO concentration by luminescence quenching has a linear response over a range of concentrations.

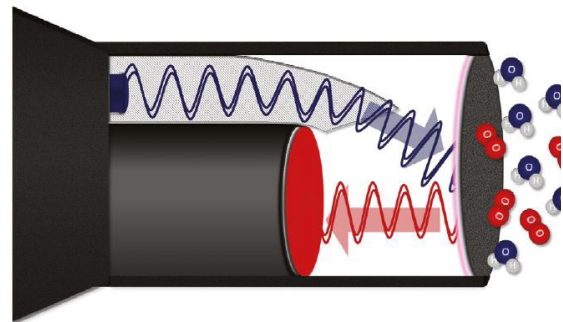

Lumiphore molecules are excited by blue light and then emit red light, which is detected by a photodiode. Optical electronics report DO concentration in mg/L.

OFFERINGS

- **Simplified integration**—use in conjunction with the 7300 monitor, SCADA/PLC Systems, or telemetry systems and HydroVu™ data services.
- **Compliance certified**—CE, FCC Class B heavy industrial immunity and emissions certifications.
- **Twist-lock cable options**—10m or custom lengths.